

NEUTRA

BATHROOM_16

NEUTRA
stone culture

Natural stone
Tradition and craftsmanship
Design and innovation
Technology
High quality finishes
Made in Italy
Bespoke

La purezza dell'acqua, l'energia della pietra, il calore del legno: il linguaggio poetico della natura diviene fonte di una nuova e piacevole cultura del benessere. NEUTRA è un'originale collezione di elementi per il bagno, wellness e living che attraverso l'armonia delle forme e l'immediatezza dei materiali riavvicina il corpo e la mente ai ritmi più autentici del vivere. Il rito quotidiano della cura di sé diventa un'esperienza avvolgente che richiama tutti i sensi, il bagno uno scenario di emozioni personali e intense che restituiscono a ciascuno la completezza del proprio essere.

Lavabi, vasche, piatti doccia e mensole dal design contemporaneo, rivestimenti dalle texture raffinate e complementi d'arredo intagliati in legni rari e preziosi sono il risultato di un dialogo ispirato tra materiali naturali e tecnologie evolute, tra sensorialità diffusa e moderna funzionalità.

Al centro di tutto è la pietra. Elemento primigenio che narra le vicende della natura e l'abilità dell'uomo nel plasmare forme assolute dalla geometria rigorosa ed essenziale. Materia viva che parla ai sensi attraverso il piacere intimo del tatto, il caldo riverbero del vapore e l'inesauribile refrigerio dell'acqua che scorre. Energia profonda che vibra e si diffonde sulle superfici per ridonare equilibrio, armonia e vitalità.

The purity of water, the energy of stones, and the warmth of wood: Nature's poetic language becomes the source of a pleasurable new approach to well being. NEUTRA is an original collection of bathroom, wellness and living furnishings and fittings whose harmony of shapes and spontaneity of materials reconcile the body and mind to the most authentic rhythms of life. The daily grooming and hygiene ritual changes into a holistic experience that brings all the senses into play. The bathroom is turned into scenario of intense personal emotions that restore the completeness of our own being in each of us.

Sinks, tubs, shower floors, and shelving all manifest contemporary design, the tiles vaunt refined textures, and the design accessories are carved from rare and precious woods. These are the result of an inspired dialogue between natural materials and evolved technologies, between a diffuse appeal to the senses and modern functionality.

Stone is at the center of everything. This primitive element narrates the events of nature and humankind's ability to mold absolute forms of rigorous, essential geometry. This natural material speaks to the senses through the intimate pleasure of touch, the warm reverberation of steam, and the inexhaustible solace of running water. The deep energy vibrates and ripples over surfaces to restore equilibrium, harmony, and vitality.



La pietra: elemento antico e naturale in grado di assumere forme differenti attraverso innovativi processi di lavorazione. Pietre uniformi o venate, morbide al tatto, rappresentano l'essenza di elementi di design creati per ambienti bagno, wellness e living.

The stone: ancient and natural material capable to be shaped in different ways through innovative manufacturing processes.

Homogeneous or veined stones, soft to the touch, are the expression of sophisticated designed elements ideal for bathroom, wellness and living spaces.

pag. 7

Lavabo d'appoggio Inkstone,
marmo Star Gold finitura lucida
(design: Steve Leung)
Mobile Neos, legno massello
Rovere Cherry, frontali pietra
Sand Brown
(design: Luca Martorano)

pag. 8-9

Vasca Inkstone, marmo
Star Gold finitura lucida
Lavabi d'appoggio Inkstone,
marmo Star Gold finitura lucida
(design: Steve Leung)
Mobile Neos, legno massello
Rovere Cherry, frontali pietra
Sand Brown
Tavolino Leaf,
base in pietra Sand Brown, top finitura Iron
(design: Luca Martorano)
Pavimento Plain, pietra Basaltina,
formato su misura

pg. 7

Inkstone wash-basin, Star Gold marble
polished finish
(design: Steve Leung)
Neos furniture, Cherry Oak solid wood,
fronts Sand Brown stone
(design: Luca Martorano)

pg. 8-9

Inkstone bathtub,
Star Gold marble polished finish
Inkstone wash-basins,
Star Gold marble polished finish
(design: Steve Leung)
Neos furniture, Cherry Oak solid wood,
fronts Sand Brown stone
Leaf side table,
base Sand Brown stone, top Iron finishing
(design: Luca Martorano)
Plain flooring, Basaltina stone,
custom sizes







pag. 10-11

Tavolino Leaf,
base pietra Sand Brown, top finitura Iron
(design: Luca Martorano)

pag. 13

Lavabo Inkstone,
marmo Star Gold finitura lucida
(design: Steve Leung)

Mobile Neos, finitura Ice Silk,
frontale pietra Sand Brown
(design: Luca Martorano)

pag. 14

Lavabo Inkstone,
marmo Star Gold finitura lucida
(design: Steve Leung)

pg. 10-11

Leaf side table,
base Sand Brown stone, top Iron finishing
(design: Luca Martorano)

pg. 13

Inkstone wash-basin,
Star Gold marble polished finish
(design: Steve Leung)

Neos furniture, Ice Silk finishing,
front Sand Brown stone
(design: Luca Martorano)

pg. 14

Inkstone wash-basin,
Star Gold marble polished finish
(design: Steve Leung)







Un progetto ispirato alla pietra da inchiostro, tradizionalmente usata nella calligrafia cinese insieme al pennello, alla carta e allo stick da inchiostro. Una collezione moderna, pura e minimalista propria dell'arte e dell'eleganza sobria tutta asiatica che si fonde con il vivere bene e la filosofia del benessere.

A design project inspired by the Chinese inkstone traditionally used for calligraphy together with the ink stick, brush and paper.

A modern, pure, and minimal collection resulting from the simple elegance and unadorned forms typical of the Asian art combined with the philosophy of well-being and luxury.

pag. 19

Vasca Inkstone, pietra Sand Brown

(design: Steve Leung)

Pavimento Earth, pietra Moon Stone,
formato 60x60 cm

(design: nespoli e novara)

pag. 20-21

Vasca Inkstone, pietra Sand Brown

Lavabi d'appoggio Inkstone,
pietra Black Rock

(design: Steve Leung)

Mobile Neos, legno massello Noce,
frontali pietra Basaltina

(design: Luca Martorano)

Rivestimento Earth, pietra Basaltina,
formato 60x60 cm

Pavimento Earth, pietra Moon Stone,
formato 60x60 cm

(design: nespoli e novara)

pg. 19

Inkstone bathtub, Sand Brown stone

(design: Steve Leung)

Earth flooring, Moon Stone,
size: 60x60 cm (roughly 24"x24")

(design: nespoli e novara)

pg. 20-21

Inkstone bathtub, Sand Brown stone

Inkstone wash-basins, Black Rock stone

(design: Steve Leung)

Neos furniture, Walnut solid wood,
fronts Basaltina stone

(design: Luca Martorano)

Earth tiles, Basaltina stone,
size: 60x60 cm (roughly 24"x24")

Earth flooring, Moon Stone,
size: 60x60 cm (roughly 24"x24")

(design: nespoli e novara)





pag. 23

Vasca Inkstone, pietra Sand Brown

(design: Steve Leung)

Rivestimento Earth, pietra Basaltina,
formato 60x60 cm

Pavimento Earth, pietra Moon Stone,
formato 60x60 cm

(design: nespoli e novara)

pg. 23

Inkstone bathtub, Sand Brown stone

(design: Steve Leung)

Earth tiles, Basaltina stone,
size: 60x60 cm (roughly 24"x24")

Earth flooring, Moon Stone,
size: 60x60 cm (roughly 24"x24")

(design: nespoli e novara)





pag. 24
Lavabi d'appoggio Inkstone,
pietra Black Rock
(design: Steve Leung)

pg. 24
Inkstone wash-basins,
Black Rock stone
(design: Steve Leung)

pag. 26-27
Lavabi d'appoggio Inkstone,
pietra Black Rock
(design: Steve Leung)
Mobile Neos, legno massello Noce,
frontali pietra Basaltina
(design: Luca Martorano)
Rivestimento Earth, pietra Basaltina,
formato 60x60 cm
Pavimento Earth, pietra Moon Stone,
formato 60x60 cm
(design: nespoli e novara)

pg. 26-27
Inkstone wash-basins,
Black Rock stone
(design: Steve Leung)
Neos furniture, Walnut solid wood,
fronts Basaltina stone
(design: Luca Martorano)
Earth tiles, Basaltina stone,
size: 60x60 cm (roughly 24"x24")
Earth flooring, Moon Stone,
size: 60x60 cm (roughly 24"x24")
(design: nespoli e novara)





pag. 28
Lavabo d'appoggio Inkstone,
pietra Basaltina
(design: Steve Leung)
Mensola Mood, legno massello Teak
(design: nespoli e novara)

pg. 28
Inkstone wash-basin,
Basaltina stone
(design: Steve Leung)
Mood shelf, Teak solid wood
(design: nespoli e novara)

pag. 30-31

Lavabo d'appoggio Inkstone,
pietra Moon Stone

(design: Steve Leung)

Mensola Plana, pietra Basaltina

(design: CRS)

Rivestimento Earth, pietra Moon Stone,
formato 60x60 cm

(design: nespoli e novara)

pg. 30-31

Inkstone wash-basin,
Moon stone

(design: Steve Leung)

Plana shelf, Basaltina stone

(design: CRS)

Earth tiles, Moon Stone,
size: 60x60 cm (roughly 24"x24")

(design: nespoli e novara)





Piani minimali, levigati, leggeri con spigoli sfuggenti; fogli visivamente sottili e inconsistenti, ma che si rivelano solidi e robusti nell'uso quotidiano. Ogni pezzo ha eleganza, cura del dettaglio, sobrietà e purezza, ma al tempo stesso ricercatezza e raffinatezza.

Minimal, smooth and light tops with rounded off corners; thin and unnoticeable sheets, turning out to be solid and strong for use in everyday life. Elegance, high-level concept design & high-quality manufacturing: a simple, pure as well as sophisticated, and tasteful style for every piece.

pag. 35

Lavabo d'appoggio Duo,
marmo Bianco Carrara
(design: Matteo Thun & Antonio Rodriguez)
Mobile Neos, legno massello Noce,
frontali marmo Bianco Carrara
(design: Luca Martorano)

pag. 36-37

Lavabi d'appoggio Duo,
marmo Bianco Carrara
(design: Matteo Thun & Antonio Rodriguez)
Mobile Neos, legno massello Noce,
frontali marmo Bianco Carrara
(design: Luca Martorano)
Vasca Alone, pietra Basaltina
Rivestimento Earth, marmo Bianco Carrara,
formato 30x60 cm
(design: nespoli e novara)

pg. 35

Duo wash-basin,
Bianco Carrara marble
(design: Matteo Thun & Antonio Rodriguez)
Neos furniture, Walnut solid wood,
fronts Bianco Carrara marble
(design: Luca Martorano)

pg. 36-37

Duo wash-basins,
Bianco Carrara marble
(design: Matteo Thun & Antonio Rodriguez)
Neos furniture, Walnut solid wood,
fronts Bianco Carrara marble
(design: Luca Martorano)
Alone bathtub, Basaltina stone
Earth tiles, Bianco Carrara marble,
size: 30x60 cm (roughly 12"x24")
(design: nespoli e novara)







pag. 39
Mobile Neos, legno massello Noce,
frontali marmo Bianco Carrara
(design: Luca Martorano)
Rivestimento Earth,
marmo Bianco Carrara,
formato 30x60 cm
(design: nespoli e novara)

pg. 39
Neos furniture, Walnut solid wood,
fronts Bianco Carrara marble
(design: Luca Martorano)
Earth tiles,
Bianco Carrara marble,
size: 30x60 cm (roughly 12"x24")
(design: nespoli e novara)





pag. 40-41
 Mobile Neos con lavabo integrato,
 pietra Pat Grey, frontali finitura Pearl silk
 (design: Luca Martorano)
 Rivestimento Earth,
 marmo Bianco Carrara,
 formato 30x60 cm
 (design: nespoli e novara)

pg. 40-41
 Neos furniture with integrated basin,
 Pat Grey stone, fronts Pearl silk finishing
 (design: Luca Martorano)
 Earth tiles,
 Bianco Carrara marble,
 size: 30x60 cm (roughly 12"x24")
 (design: nespoli e novara)





pag. 42-43
Lavabi d'appoggio Duo, pietra Pat Grey
(design: Matteo Thun & Antonio Rodriguez)
Mobile Neos, finitura Mohair silk,
frontali pietra Pat Grey
(design: Luca Martorano)
Rivestimento Earth, pietra Basaltina,
formato 60x60 cm
(design: nespoli e novara)

pg. 42-43
Duo wash-basins, Pat Grey stone
(design: Matteo Thun & Antonio Rodriguez)
Neos furniture, Mohair silk finishing,
fronts Pat Grey stone
(design: Luca Martorano)
Earth tiles, Basaltina stone,
size: 60x60 cm (roughly 24"x24")
(design: nespoli e novara)



pag. 44-45

Lavabo sospeso Square Tailor,
pietra Silver Stone
(design: nespoli e novara)
Mobile Neos, finitura Pearl silk,
frontali pietra Silver Stone
(design: Luca Martorano)

pg. 44-45

Square Tailor wall mounted wash-basin,
Silver Stone
(design: nespoli e novara)
Neos furniture, Pearl silk finishing,
fronts Silver Stone
(design: Luca Martorano)





Alla vista inconsistenza e immaterialità.
Al tatto solidità e robustezza. Il rigore geometrico conferisce un ritmo alla composizione e annulla l'effetto volumetrico dei singoli elementi.
Sensory details appealing to sight and touch: light & immaterial, but also solid & sturdy.
A geometrical rigorous style instills a sense of rhythm in the composition by minimizing the volume effect of every piece.



to fresco la Estate, e farà
iare le possessioni, i Giare
auer fiumi navigabili; si co
osi sopra tutto dalle acque morte, e
fabriheremo

VI-SU. 00000000

pag. 48-49

Mobile Neos, legno massello Noce,
frontali pietra Sinai

(design: Luca Martorano)

Lavabi d'appoggio Egg, pietra Sinai

Vasca Convivium, pietra Pat Grey

(design: nespoli e novara)

pag. 51

Mobile Neos, legno massello Noce,
frontali pietra Sinai

(design: Luca Martorano)

Lavabi d'appoggio Egg, pietra Sinai

(design: nespoli e novara)

pg. 48-49

Neos furniture, Walnut solid wood,
fronts Sinai stone

(design: Luca Martorano)

Egg wash-basins, Sinai stone

Convivium bathtub, Pat Grey stone

(design: nespoli e novara)

pg. 51

Neos furniture, Walnut solid wood,
fronts Sinai stone

(design: Luca Martorano)

Egg wash-basins, Sinai stone

(design: nespoli e novara)





pag. 52

Lavabo d'appoggio Inkstone,
pietra Sand Brown
(design: Steve Leung)

pag. 55

Lavabo d'appoggio Inkstone,
pietra Sand Brown
(design: Steve Leung)
Mobile Neos, finitura Ice silk,
frontale pietra Sand Brown
(design: Luca Martorano)

pg. 52

Inkstone wash-basin,
Sand Brown stone
(design: Steve Leung)

pg. 55

Inkstone wash-basin,
Sand Brown stone
(design: Steve Leung)
Neos furniture, Ice silk finishing,
front Sand Brown stone
(design: Luca Martorano)





Atmosfere vaporose e avvolgenti
per un piacere antico e senza tempo.
Superfici morbide da attraversare lentamente
per godere di un rilassante massaggio.
Profili sinuosi che avvolgono il corpo
e accarezzano la vista.
Vaporous and holistic atmospheres
provide timeless, ancient pleasure.
The soft surfaces lead you slowly through
them to enjoy a relaxing massage.
Sinuous silhouettes that wrap your body
and caress your vision.

pag. 59

Vasca Alone, pietra Sinai
Vassoio Dual, legno massello
Rovere Cherry
(design: nespoli e novara)

pag. 60-61

Vasca Alone, pietra Sinai
Vassoio Dual, legno massello
Rovere Cherry
Rivestimento Earth, pietra Sinai,
formato 30x60 cm (in alto)
Rivestimento Cube, pietra Sinai,
formato 30x60 cm (in basso)
Rivestimento Random, pietra Moon Stone,
formato 60x60 cm
Monoliti Baobab, pietra Moon Stone
(design: nespoli e novara)

pg. 59

Alone bathtub, Sinai
Dual tray, Cherry Oak solid wood
(design: nespoli e novara)

pg. 60-61

Alone bathtub, Sinai stone
Dual tray, Cherry Oak solid wood
Earth tiles, Sinai stone, size: 30x60 cm,
(roughly 12"x24") (above)
Cube tiles, Sinai stone, size: 30x60 cm,
(roughly 12"x24") (below)
Random tiles, Moon Stone,
size: 60x60 cm (roughly 24"x24")
Baobab monoliths, Moon Stone
(design: nespoli e novara)





pag. 62

Rivestimento Random, pietra
Moon Stone, formato 60x60 cm
(design: nespoli e novara)

pag. 63

Rivestimento Cube, pietra Sinai,
formato 30x60 cm

Vasca Alone, pietra Sinai

Vassoio Dual,
legno massello Rovere Cherry

(design: nespoli e novara)

pg. 62

Random tiles, Moon Stone
size: 60x60 cm (roughly 24"x24")
(design: nespoli e novara)

pg. 63

Cube tiles, Sinai stone,
size: 30x60 cm (roughly 12"x24")

Alone bathtub, Sinai stone

Dual tray, Cherry Oak solid wood

(design: nespoli e novara)



pag. 65

Monoliti Minimal, pietra Sinai
(design: nespoli e novara)

pag. 66

Rivestimento Cube, pietra Sinai,
formato 30x60 cm
(design: nespoli e novara)

pg. 65

Minimal monoliths, Sinai
(design: nespoli e novara)

pg. 66

Cube tiles, Sinai stone, size: 30x60 cm
(roughly 12"x24")
(design: nespoli e novara)







Ambienti solari e luminosi, reticoli di linee che si espandono in ogni direzione. Alchimie di materiali per habitat minimalisti e raffinati, dove svanisce il confine tra design e architettura. Bright rooms have lattices that extend in all directions. The alchemies of materials in minimal, refined habitats let the border between design and architecture vanish.





pag. 71
Vasca SPA, pietra Basaltina
(design: nespoli e novara)

pag. 72-73
Rivestimento Earth, marmo Bianco Carrara, formato 60x60 cm
Rivestimento Chelsea, marmo Bianco Carrara, formato 60x60 cm (al centro)

Vasca SPA, pietra Basaltina
Lavabo d'appoggio Nest, marmo Bianco Carrara (design: nespoli e novara)
Mensola Plana, pietra Basaltina (design: CRS)

pag. 74
Lavabo d'appoggio Nest, marmo Bianco Carrara (design: nespoli e novara)
Mensola Plana, pietra Basaltina (design: CRS)

pag. 75
Rivestimento Chelsea, marmo Bianco Carrara, formato 60x60 cm (design: nespoli e novara)

pg. 71
SPA bathtub, Basaltina stone
(design: nespoli e novara)

pg. 72-73
Earth tiles, Bianco Carrara marble, size: 60x60 cm (roughly 24"x24")
Chelsea tiles, Bianco Carrara marble, size: 60x60 cm (roughly 24"x24") (in the centre)

SPA bathtub, Basaltina stone
Nest wash-basin, Bianco Carrara marble (design: nespoli e novara)
Plana shelf, Basaltina stone (design: CRS)

pg. 74
Nest wash-basin, Bianco Carrara marble (design: nespoli e novara)
Plana shelf, Basaltina stone (design: CRS)

pg. 75
Chelsea tiles, Bianco Carrara marble size: 60x60 cm (roughly 24"x24") (design: nespoli e novara)









pag. 76-77

Lavabo d'appoggio Fluid,
pietra Moon Stone

Mobile a giorno Moody,
legno massello Rovere
(design: CRS)

pag. 78-79

Lavabo a parete Fluid,
pietra Black Rock
(design: CRS)

pag. 80

Lavabo a parete Slide,
pietra Sinai
(design: CRS)

pg. 76-77

Fluid wall mounted wash-basin,
Moon Stone

Moody furniture, Oak solid wood
(design: CRS)

pg. 78-79

Fluid wall mounted wash-basin,
Black Rock stone
(design: CRS)

pg. 80

Slide wall mounted wash-basin,
Sinai stone
(design: CRS)





Composizioni armoniose di legno e pietra interpretate da Matteo Thun, pioniere del design sostenibile. Superfici levigate che si tramutano in pelle di legni preziosi. Una collezione affascinante di pezzi unici in rarissimo Kauri, legno fossile privo di venature dalle paludi neozelandesi: l'arte sposa l'ecologia. These harmonious compositions of wood and stone have been interpreted by Matteo Thun, pioneer of sustainable design. Polished surfaces turn into the supple skin of precious woods. This glamorous collection of unique pieces is made of very rare Kauri, an ungrained fossil wood from the millenary swamps of New Zealand. Art marries ecology.



pag. 84-85

Vasca Duo, pietra Moon Stone, legno Kauri
(design: Matteo Thun & Antonio Rodriguez)

pag. 87

Rivestimento Earth, pietra Sinai,
formato 30x60 cm
(design: nespoli e novara)

Lavabi d'appoggio Duo, pietra Moon Stone
Mensola Duo, legno Kauri
(design: Matteo Thun & Antonio Rodriguez)

pag. 88-89

Rivestimento Earth, pietra Sinai,
formato 30x60 cm
(design: nespoli e novara)

Vasca Duo, pietra Moon Stone, legno Kauri
(design: Matteo Thun & Antonio Rodriguez)

pg. 84-85

Duo bathtub, Moon Stone, Kauri wood
(design: Matteo Thun & Antonio Rodriguez)

pg. 87

Earth tiles, Sinai stone, size 30x60 cm
(roughly 12"x24")
(design: nespoli e novara)

Duo wash-basins, Moon Stone
Duo shelf, Kauri wood
(design: Matteo Thun & Antonio Rodriguez)

pg. 88-89

Earth tiles, Sinai stone, size 30x60 cm
(roughly 12"x24")
(design: nespoli e novara)

Duo bathtub, Moon Stone, Kauri wood
(design: Matteo Thun & Antonio Rodriguez)







pag. 90

Rivestimento Earth,
pietra Basaltina,
formato 60x60 cm (a sinistra)

Rivestimento Graffiti,
pietra Basaltina,
formato 60x60 cm (a destra)

(design: nespoli e novara)

Monolito Duo, pietra Moon Stone,
legno massello Noce

(design: Matteo Thun & Antonio Rodriguez)

pag. 92-93

Rivestimento Earth,
pietra Basaltina,
formato 60x60 cm

(design: nespoli e novara)

Vasca Duo, pietra Moon Stone,
legno massello Noce

Monoliti Duo, pietra Moon Stone,
legno massello Noce

(design: Matteo Thun & Antonio Rodriguez)

pg. 90

Earth tiles, Basaltina stone,
size 60x60 cm (roughly 24"x24")
(on the left)

Graffiti tiles, Basaltina stone,
size 60x60 cm (roughly 24"x24")
(on the right)

Duo monolith, Moon Stone, Walnut solid wood
(design: Matteo Thun & Antonio Rodriguez)

pg. 92-93

Earth tiles, Basaltina stone,
size 60x60 cm (roughly 24"x24")

Duo bathtub, Moon Stone, Walnut solid wood

Duo monoliths, Moon Stone, Walnut solid wood
(design: Matteo Thun & Antonio Rodriguez)





pag. 94
Piatto doccia Duo, pietra Moon Stone,
legno massello Noce
(design: Matteo Thun & Antonio Rodriguez)

pg. 94
Duo shower tray, Moon Stone,
Walnut solid wood
(design: Matteo Thun & Antonio Rodriguez)

pag. 95
Lavabi d'appoggio Duo, pietra Moon Stone
Mensola Duo, legno massello Noce
(design: Matteo Thun & Antonio Rodriguez)

pg. 95
Duo wash-basins, Moon Stone
Duo shelf, Walnut solid wood
(design: Matteo Thun & Antonio Rodriguez)



Forme primarie ed essenziali, archetipi di una purezza originaria che accompagnano i gesti semplici del bagno quotidiano. Luci mutevoli che scivolano sui basalti levigati per rapprendersi sulla trama incisa delle pareti.

Primary, essential shapes, the archetypes of original purity accompany the simple gestures of the everyday bathroom. Changing lights slide along the polished basalt and then take form in the tracteries etched on the walls.

pag. 99

Vasca Duo, marmo Bianco Carrara
(design: Matteo Thun & Antonio Rodriguez)
Vassoio Bridge, legno massello Rovere
(design: nespoli e novara)

pag. 100-101

Rivestimento Graffiti, pietra Basaltina,
formato 60x60 cm
(a sinistra)

Rivestimento Earth, pietra Basaltina,
formato 60x60 cm
(a destra)

Vassoio Bridge, legno massello Rovere

Lavabi a parete Square,
pietra Basaltina

(design: nespoli e novara)

Contenitore Soul, pietra Basaltina

(design: CRS)

Vasca Duo, marmo Bianco Carrara

(design: Matteo Thun & Antonio Rodriguez)

pg. 99

Duo bathtub, Bianco Carrara marble
(design: Matteo Thun & Antonio Rodriguez)
Bridge tray, Oak solid wood
(design: nespoli e novara)

pg. 100-101

Graffiti tiles, Basaltina stone
size: 60x60 cm (roughly 24"x24")
(on the left)

Earth tiles, Basaltina stone
size: 60x60 cm (roughly 24"x24")
(on the right)

Bridge tray, Oak solid wood

Square wall mounted wash-basins,
Basaltina stone

(design: nespoli e novara)

Soul shelving, Basaltina stone

(design: CRS)

Duo bathtub, Bianco Carrara marble

(design: Matteo Thun & Antonio Rodriguez)





pag. 102
Contenitore Soul,
pietra Basaltina
(design: CRS)

pag. 103
Lavabi a parete Square,
pietra Basaltina
(design: nespoli e novara)

pg. 102
Soul shelving, Basaltina stone
(design: CRS)

pg. 103
Square wall mounted wash-basins,
Basaltina stone
(design: nespoli e novara)





pag. 104-105-107

Rivestimento Earth,
pietra Basaltina
formato 60x60 cm
(design: nespoli e novara)
Monoliti Duo, pietra Moon Stone
(design: Matteo Thun & Antonio Rodriguez)

pag. 108-109

Rivestimento Graffiti,
pietra Basaltina
formato 60x60 cm (a sinistra)
Rivestimento Earth,
pietra Basaltina
formato 60x60 cm (a destra)
Lavabi d'appoggio Flute, pietra Moon Stone
Mensola Mood, legno massello Rovere
(design: nespoli e novara)

pag. 110

Lavabi d'appoggio Flute, pietra Moon Stone
Mensola Mood, legno massello Rovere
(design: nespoli e novara)

pg. 104-105-107

Earth tiles, Basaltina stone,
size 60x60 cm (roughly 24"x24")
(design: nespoli e novara)
Duo monoliths, Moon Stone
(design: Matteo Thun & Antonio Rodriguez)

pg. 108-109

Graffiti tiles, Basaltina stone,
size 60x60 cm (roughly 24"x24")
(on the left)
Earth tiles, Basaltina stone,
size 60x60 cm (roughly 24"x24")
(on the right)
Flute wash-basins, Moon Stone
Mood shelf, Oak solid wood
(design: nespoli e novara)

pg. 110

Flute wash-basins, Moon Stone
Mood shelf, Oak solid wood
(design: nespoli e novara)







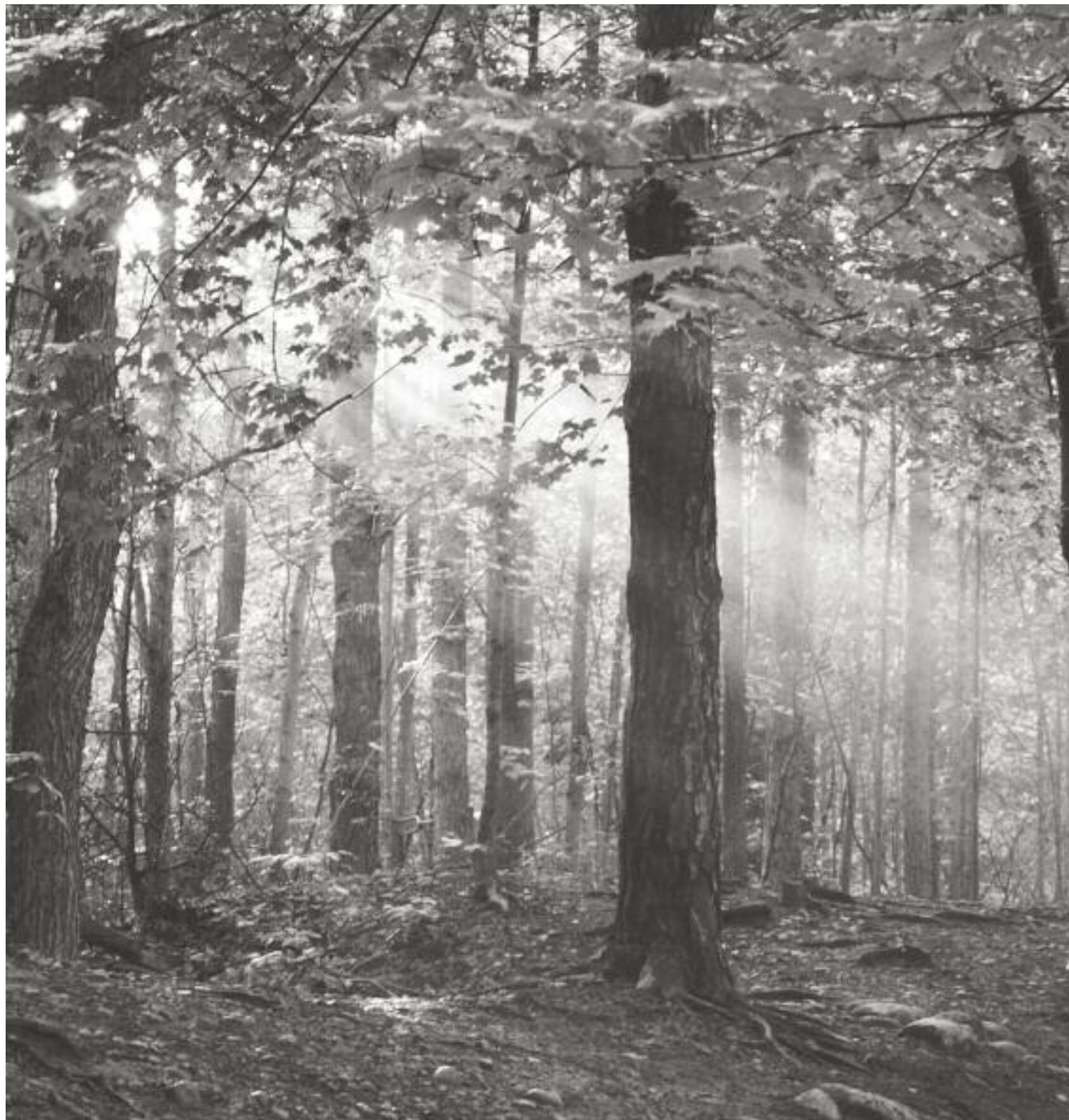

Abitudini di un'eleganza esclusiva e contemporanea. Lucide essenze tropicali, texture scultoree che vibrano nello spazio ed evocano l'energia potente della materia. Presenze luminose discrete e personalizzabili, tra funzionalità e cromoterapia. Certain habits have an exclusive, contemporary elegance. Shiny tropical essences and sculptural textures vibrate in space and bring forth the potent energy of the material. Their luminous presence is discreet and personalizable, blending functionality and chromotherapy.

pag. 115
Vasca Convivium, pietra Black Rock
(design: nespoli e novara)

pg. 115
Convivium bathtub, Black Rock stone
(design: nespoli e novara)





pag. 116-117

Rivestimento Augmented Texture serie Striped Led,
pietra Black Rock,
formato 50x50 cm/25x100 cm

(concept: **ethos**[™]+ design: Elia Nedkov)

Vasca Convivium, pietra Black Rock

Piatto doccia Domino Tailor, marmo Bianco Carrara

Lavabi a parete Ego, marmo Bianco Carrara

(design: nespoli e novara)

pag. 119

Rivestimento Augmented Texture serie Striped Led,
pietra Black Rock,
formato 50x50 cm/25x100 cm

(concept: **ethos**[™]+ design: Elia Nedkov)

Piatto doccia Domino Tailor, marmo Bianco Carrara

(design: nespoli e novara)

pg. 116-117

Augmented Texture Striped Led Series tiles,
Black Rock stone, size: 50x50 cm (roughly 24"x24")/
25x100 cm (roughly 10"x40")

(concept: **ethos**[™]+ design: Elia Nedkov)

Convivium bathtub, Black Rock stone

Domino Tailor shower tray, Bianco Carrara marble

Ego wall mounted wash-basins,

Bianco Carrara marble

(design: nespoli e novara)

pg. 119

Augmented Texture Striped Led Series tiles,
Black Rock, size: 50x50 cm (roughly
24"x24")/25x100 cm (roughly 10"x40")

(concept: **ethos**[™]+ design: Elia Nedkov)

Domino Tailor shower tray, Bianco Carrara marble

(design: nespoli e novara)





pag. 120
Lavabo d'appoggio Air,
pietra Sinai
(design: nespoli e novara)

pag. 121
Lavabi d'appoggio Air, pietra Sinai
Mensola Mood, legno massello Teak,
(design: nespoli e novara)

pg. 120
Air wash-basin, Sinai stone
(design: nespoli e novara)

pg. 121
Air wash-basins, Sinai stone
Mood shelf, Teak solid wood
(design: nespoli e novara)





pag. 122-123
Monolito Sign, pietra Black Rock
(design: nespoli e novara)

pag. 125-126-127
Lavabo a parete Round Tailor,
marmo Bianco Carrara
(design: nespoli e novara)

pg. 122-123
Sign monolith, Black Rock stone
(design: nespoli e novara)

pg. 125-126-127
Round Tailor wall mounted wash-basin,
Bianco Carrara marble
(design: nespoli e novara)





NEUTRA è una collezione creata da un marchio di antica tradizione nel campo dei materiali lapidei.

Gli elementi realizzati con nove varietà di pietra provenienti da cave selezionate in Italia e all'estero vengono scavati a partire da un singolo massello, lavorati con tecnologie di avanguardia e rifiniti a mano per ottenere un tocco morbido e vellutato. Una perfetta miscela di creatività, passione artigianale e alta professionalità che esprime l'essenza più genuina del Made in Italy.

NEUTRA is a collection created by a hallmarked company of the ancient tradition in stone.

These items are created with nine varieties of stone coming from select quarries in Italy and abroad, and are carved from a single block of stone. Then they are worked with avant garde technologies and hand finished to a soft, velvety touch. This perfect mix of creativity, artisanal passion, and high professionalism expresses the most genuine essence of Made in Italy.

La pietra è un prodotto naturale in cui le irregolarità visibili sono in effetti delle caratteristiche ben precise del materiale. La campionatura delle pietre NEUTRA ha un valore puramente indicativo in quanto non è possibile mostrare tutte le naturali variazioni della pietra, la granulosità effettiva, le sfumature di colore, la presenza eventuale di fossili, vene, filamenti, nodi, occhi, etc. che si evidenziano man mano che si lavora il blocco di pietra.

Stone is a natural product whose visible irregularities are actually quite precise characteristics of the material. The samples of NEUTRA stones are purely indicative since it is impossible to show all the natural variations of a stone, its actual granularity and nuances in color, or the presence of any fossils, veins, filaments, knots, eyes, etc. that emerge little by little as the block of stone is carved.

Basaltina

Pietra lavica di colore grigio, a struttura compatta con tessuto granulare, può presentare zone di diverse densità e sfumature di colore dal grigio a marrone.

This grey lava stone has a compact structure with a granular texture. It may have zones of varying density and tints range from grey to brown.



Moon Stone

Pietra compatta di origine sedimentaria a grana fine con frammenti fossili o di pasta calcarea color crema/beige.
This compact fine-grained sedimentary stone contains fossil fragments, and cream or beige calcareous colorations.



Star Gold

Marmo di origine metamorfica, a grana fine, di colore bianco avorio con venature ondulate color grigio/marrone.
This fine-grained marble has a metamorphic origin and it is ivory-colored with wavy grey and brown veins.



Black Rock

Quarzite di colore nero intenso con sottili venature bianche, di grana finissima e di origine metamorfica con natura silicea e scistosa.
This black quartzite with thin white veins and very fine grain has a metamorphic origin with a schistose and siliceous nature.

This black quartzite with thin white veins and very fine grain has a metamorphic origin with a schistose and siliceous nature.

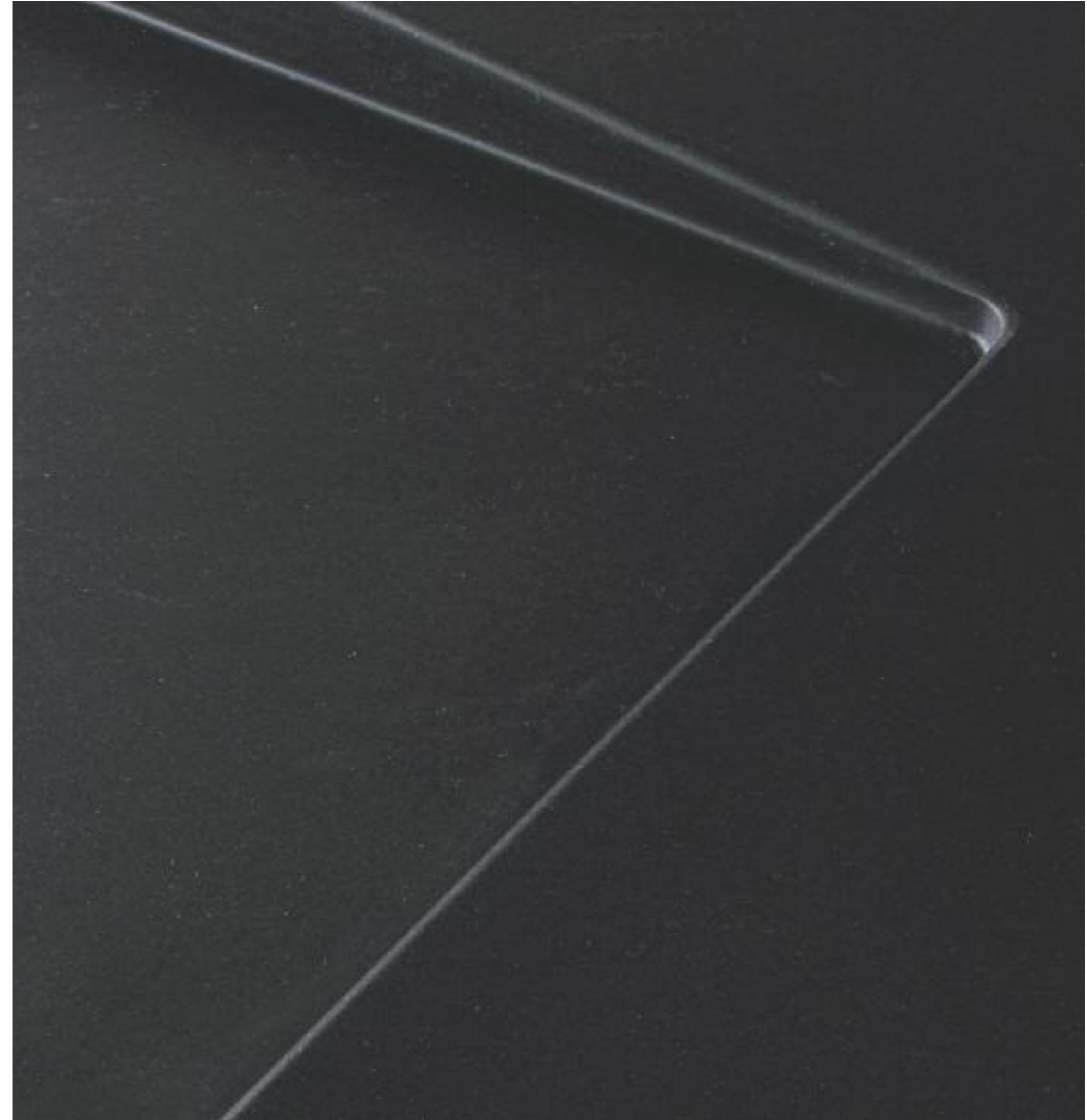

Sinai

Pietra arenaria compatta e uniforme di colore grigio-verde, con presenza di magrosità e "occhi ovali" di tonalità e consistenza sedimentaria differente.

This compact, uniform grey-green sandstone may have matte patches and oval spots with differing tonality and consistency from a different sedimentation.



Pat Grey

Pietra compatta ed omogenea di origine metamorfica con grana medio-fine, è caratterizzata da un colore grigio tendente a tonalità calde. Può presentare piccole venature di colore nero.

This compact, uniform and fine-grained stone is warm grey-colored. It may presents some little darker veins.



Sand Brown

Pietra di colore marrone chiaro e di grana medio-fine, presenta sottili venature più scure che contribuiscono a dare eleganza e calore a questo materiale.

Light-brown and fine-grained stone may have thin darker veins giving elegance and warmth to this material.



Bianco Carrara

Marmo di colore variabile dal bianco livido al grigio chiaro, a grana media, con venature grigie e fasce bianche non uniformi dovute alla presenza di pirite microcristallina.

This marble varies from mottled white to light grey with a medium grain. It has grey veins and irregular white stripes due to the presence of microcrystalline pyrite.



Silver Stone

Pietra arenaria di colore grigio con un elevato grado di opacità e granulometria variabile per la presenza di puntini lucenti dovuti a scagliette di mica.

This grey sandstone with has great opacity and variable granulosity, due to the presence of bright spots of mica flakes.



Legni - Wood

Tutti i legni della collezione NEUTRA sono legni a massello e/o massicci trattati ad olio. Eventuali movimenti del legno, piccole crepe e mutamenti nel corso del tempo, non possono essere imputabili a reclami o imperfezioni del prodotto, bensì ad un naturale assestamento del legno in base alle diverse condizioni ambientali.

Every piece of NEUTRA collection wood is solid wood and/or massive oil-treated. Any movement in the wood, little cracks and changes that might occur over time cannot be considered grounds for complaint as they are due not to imperfections in the material but rather to a natural settling of the wood in reaction to various environmental conditions.

Noce - Walnut



Cedro - Cedar



Rovere - Oak



Kauri



Rovere Cherry - Cherry Oak



Teak



Silk

Silk è una finitura in grado di conferire alla superficie in legno un aspetto tattile e visivo simile al tessuto. La piacevolezza al tatto, la sensazione di calore e l'alta resistenza nel tempo contraddistinguono questa finitura totalmente innovativa.

Silk is a finishing similar to the texture appealing to sight and touch. The pleasantness to the touch, the warmth sensation and the high resistance mark this completely innovative finishing: the wooden surface becomes softer.

Pearl silk

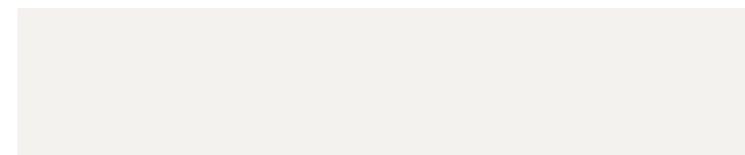

Ice silk

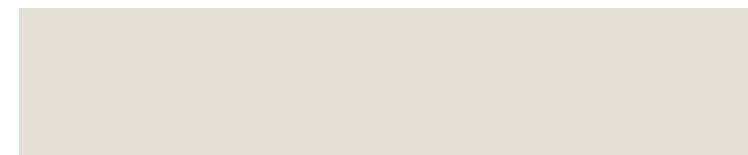

Mohair silk



Havana silk





STEVE LEUNG

Architetto, Interior e Product Designer, nasce nel 1957 a Hong Kong dove consegue la laurea in Architettura e il Master in Pianificazione Urbana. Nel 1987 apre il suo studio di Progettazione Architettonica e Urbana con sede principale a Hong Kong e filiali a Pechino, Shanghai, Guangzhou e Chengdu. 13 volte vincitore dell'Andrew Martin International Award, l'Oscar del Design, è stato definito nel 2015 da INTERNI una delle 50 persone più influenti a livello mondiale e uno dei 30 Designers più influenti da FORBES China. Ad oggi il suo studio ha ricevuto crediti di oltre 130 premi in Asia e in tutto il mondo. Nel 2014 e 2015 Steve ha dato vita ad altre tre società specializzate in design e servizi in vari campi guidate dal motto "DESIGN WITHOUT LIMITS".

Architect, Interior and Product Designer, born in 1957 in Hong Kong, he graduated in Architecture and got a Master's Degree in Urban Planning. In 1987 he opened his Urban and Architectural Planning Office with headquarter in Hong Kong and branches in Beijing, Shanghai, Guangzhou and Chengdu. The thirteen-time winner of the Andrew Martin International Award, the Design Oscar, is considered one of The 50 Most Influential Person of the Year 2015 by INTERNI and The 30 Most Influential Designers by FORBES China. Up to now his Office has won more than 130 design and corporate awards in Asia Pacific Region and worldwide. With "DESIGN WITHOUT LIMITS" as motto, Steve set up three more brands for specialized design and diversified services in 2014 and 2015.



LUCA MARTORANO

Nato nel 1980 vicino a Bolzano, studia al Politecnico di Milano, dove entra in contatto con Enzo Mari, Andrea Branzi, Ezio Manzini. Nel 2005 si laurea cum Laude con una tesi su sistemi di trasporto sostenibili, presentata l'anno seguente al MoMa di New York. Tra il 2007 e il 2010 collabora con lo studio di Toan Nguyen prima e di Matteo Thun poi; nel 2011 si sposta a Londra, dove disegna per due brand inglesi di interior design. Dal 2012 si stabilisce a Bolzano dove tutt'ora vive e lavora. La predilezione di forme sobrie e pulite e la sensibilità verso i materiali naturali lo hanno gradualmente orientato a delle produzioni di qualità e alla costante ricerca di un equilibrio ideale tra tecnica e stile.

Born in 1980 in Bolzano, he studied at Milan Politecnico University where he got in touch with Enzo Mari, Andrea Branzi and Ezio Manzini. In 2005 he graduated "cum Laude" defending a thesis about the sustainable systems of transport, presented at MoMa New York the following year. Between 2007 and 2010 he cooperated with Toan Nguyen's and Matteo Thun's offices; in 2011 he moved to London designing for two major English interior brands. Since 2012 he has been based in Bolzano where he is currently living and working. His predilection for sober and clean forms as well as his awareness of natural materials gradually oriented him towards quality productions and the constant pursuit of the balance between technique and style.



ELIA NEDKOV

Nato in Bulgaria nel 1971 ma di nazionalità austriaca, studia moda a Vienna e in seguito, architettura presso il Politecnico di Graz dove, nel 1998, fonda uno studio specializzato in architettura, design e grafica, ispirato dai principi guida della sensibilità e semplicità. Nel 2003 trasferisce il suo studio a Milano, dove lavora a tutt'oggi come architetto, designer e direttore artistico. Ha ottenuto riconoscimenti internazionali tra cui il "Polydecor Design Award" e la vittoria del concorso "DuPont Corian for a food & coffee bar". Uno dei suoi progetti è citato tra i 100 progetti all'avanguardia del 2014, nel settore del retail design. Nel 2015 riceve il premio "Best Project" da Archilovers.

A Bulgarian-born Austrian citizen, Nedkov has studied fashion in Vienna and then architecture in Graz, Austria. In 1998, he opened his studio in Graz specializing in architecture, design, and graphics, developing his personal approach based on sensibility and simplicity. In 2003 he moved his studio to Milan where he works as architect, designer and art director. He has been awarded various international awards such as the "Polydecor Design Award" and has won the "DuPont Corian for a food & coffee bar" competition. One of his projects was inserted in the list of 100 cutting-edge retail design projects of 2014. He was awarded with the "Best Project 2015" award from Archilovers.



nespoli e novara

Ambrogio Matteo Nespoli e Alberto Novara, nascono a Seregno negli anni 1969-1970, aprono lo studio di progettazione nel 2000 e si laureano in architettura al Politecnico di Milano nel 1996-1998. Si occupano di ristrutturazioni conservative di edifici privati, pianificazioni di spazi per il lavoro, uffici, spazi commerciali, showroom, prodotti per aziende di arredamento. Lo studio è inoltre attivo nella comunicazione aziendale e realizza progetti di immagine coordinata e allestimenti. Collaborano con: Zucchetti, Graff, Riva 1920, Friul Mosaic Yourbeer, Calzaturificio Romano Martegani 1891, Neutra, Rapsel, Vola, Nito, Quality-Bau, Toscoquattro. Le loro creazioni sono comparse più volte su importanti riviste nazionali e internazionali come "Interni", "Elle Decor" e "Wallpaper".

Ambrogio Matteo Nespoli and Alberto Novara were born in Seregno in 1969 and in 1970. They graduated in Architecture at the Politecnico di Milano and opened the Studio in the year 2000. They have worked on residential sites, the restructuring of private buildings, planning of workspace, offices, commercial spaces, showrooms and products for furniture companies. nespoli e novara worked for companies like Zucchetti, Graff, Riva 1920, Friul Mosaic Yourbeer, Calzaturificio Romano Martegani 1891, Neutra, Rapsel, Vola, Nito, Quality-Bau, Toscoquattro. The Studio is also active in corporate communication and implements corporate image projects and productions. Their creations have appeared on national and international journals as "Interni", "Elle Decor" and "Wallpaper".



MATTEO THUN

Nato a Bolzano nel 1952, ha studiato all'Accademia di Salisburgo con Oskar Kokoschka laureandosi poi in Architettura a Firenze con Adolfo Natalini. Ha collaborato per alcuni anni con Ettore Sottsass. Nel 1984 ha aperto un proprio studio a Milano e nel decennio successivo è stato direttore creativo di Swatch. Designer e architetto di fama mondiale, particolarmente attento ai temi della sostenibilità, del benessere e della relazione tra uomo e natura, ha conquistato tre volte il *Compasso d'Oro* ed è membro della prestigiosa Royal Association of British Architects.

Born in Bolzano in 1952, Matteo Thun studied at the Academy of Salzburg with Oskar Kokoschka and then graduated in architecture in Florence under Adolfo Natalini. He collaborated with Ettore Sottsass for a few years. In 1984, he opened his own studio in Milan was the creative director at Swatch the following decade. Thun is a world famous architect and designer, especially attentive to the issue of sustainability, well being, and the relationship between people and nature. He has won the Italian *Compasso d'Oro* industrial design award three times and he is a member of the prestigious Royal Association of British Architects.

INKSTONE COLLECTION by Steve Leung

Inkstone 01

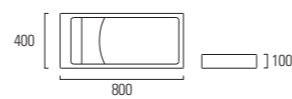

Inkstone 02

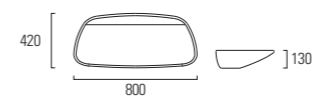

Inkstone 03

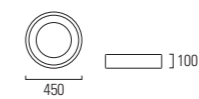

Inkstone 04



Inkstone Bathtub

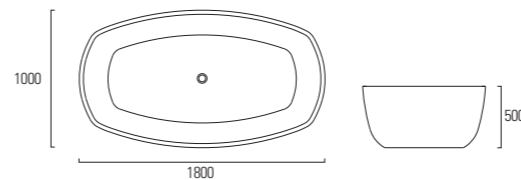

DUO COLLECTION by Matteo Thun & Antonio Rodrigues

Duo B 3415



Duo B 3437



Duo M7

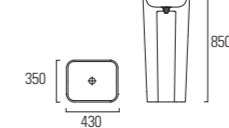

Duo M7P

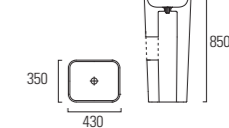

Duo B 3437 + BLM

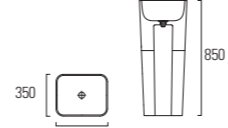

Duo B 3437 + BLM P

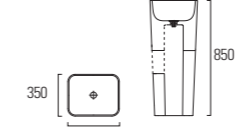

Duo D 91015

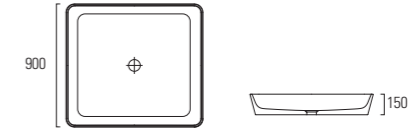

Duo BLD

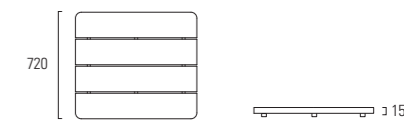

Duo V5

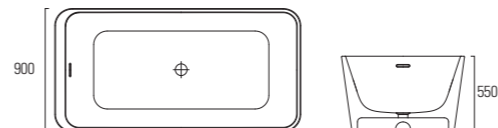

Duo V6 + BLV

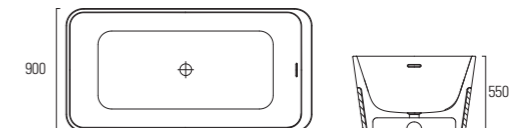

Duo M

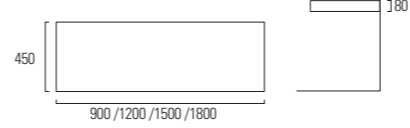

Duo V6 + TLV

penisola in legno Kauri a richiesta secondo disponibilità
Kauri wood board on request according to availability

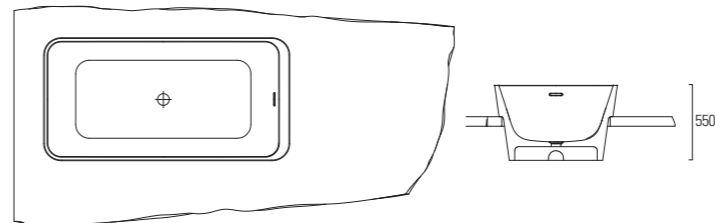

Duo MK

mensola in legno Kauri a richiesta secondo disponibilità
Kauri wood shelf on request according to availability

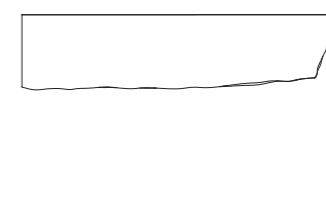

EGG by nespoli e novara

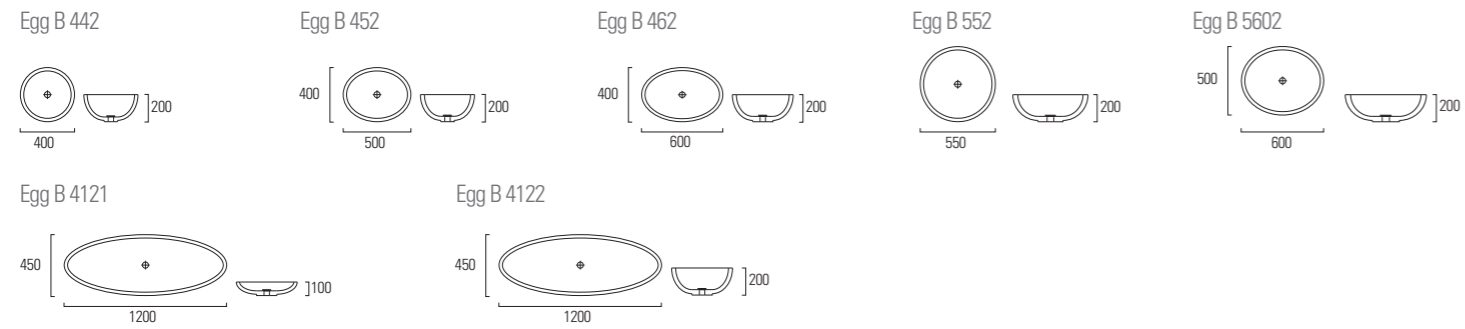

EGO by nespoli e novara



FLUTE by nespoli e novara

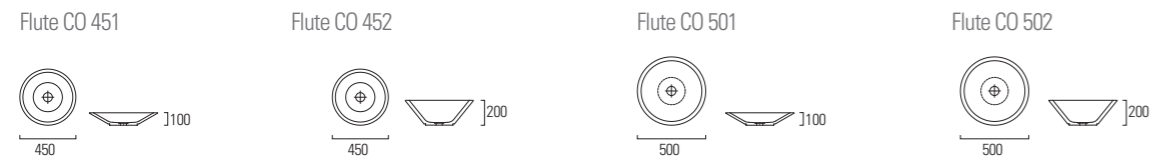

AIR by nespoli e novara



NEST by nespoli e novara

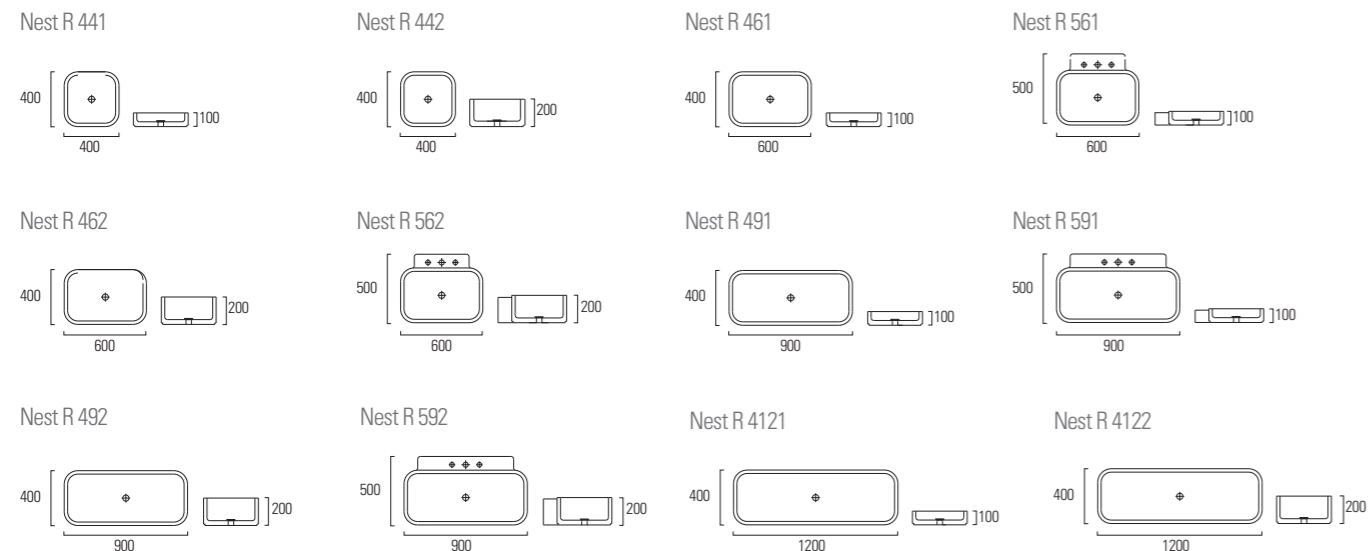

SQUARE by nespoli e novara

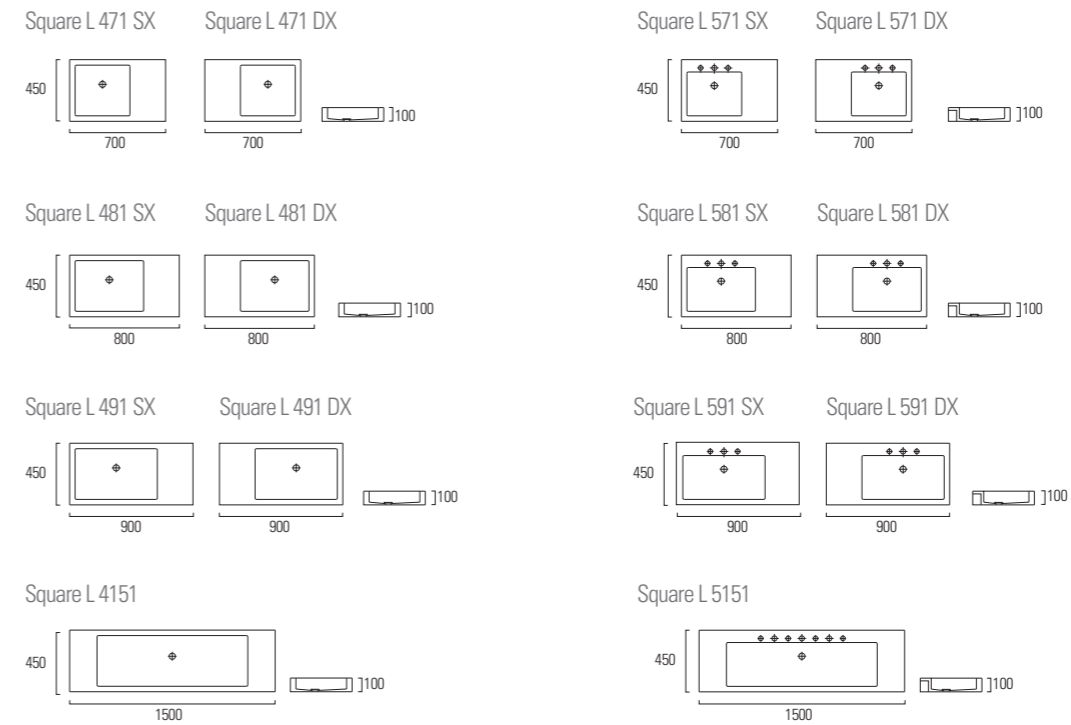

MINI SQUARE by CRS

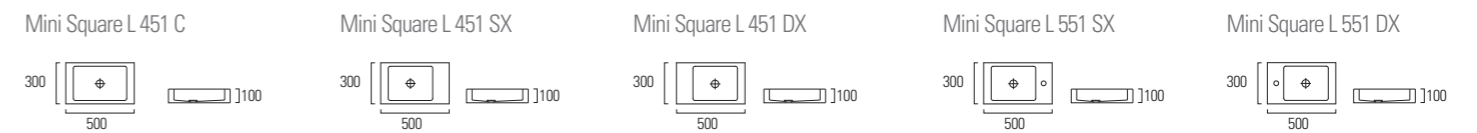

SQUARE TAILOR by nespoli e novara

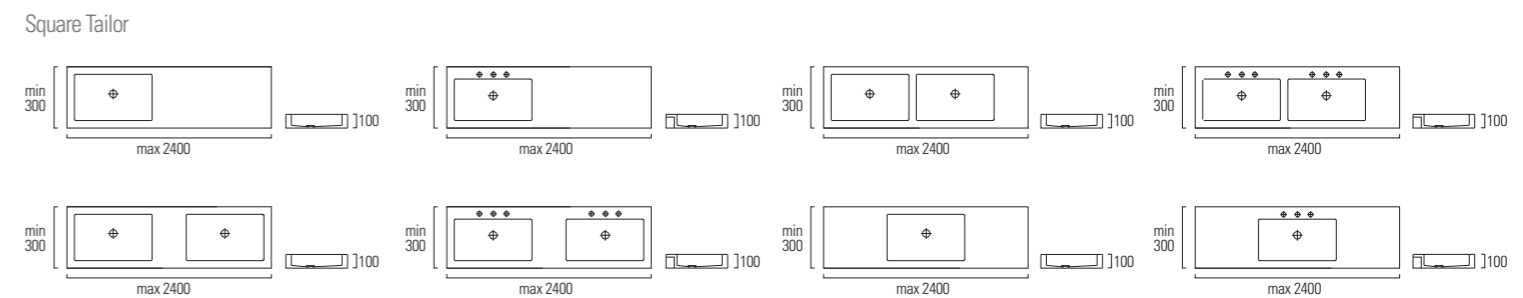

ROUND by nespoli e novara

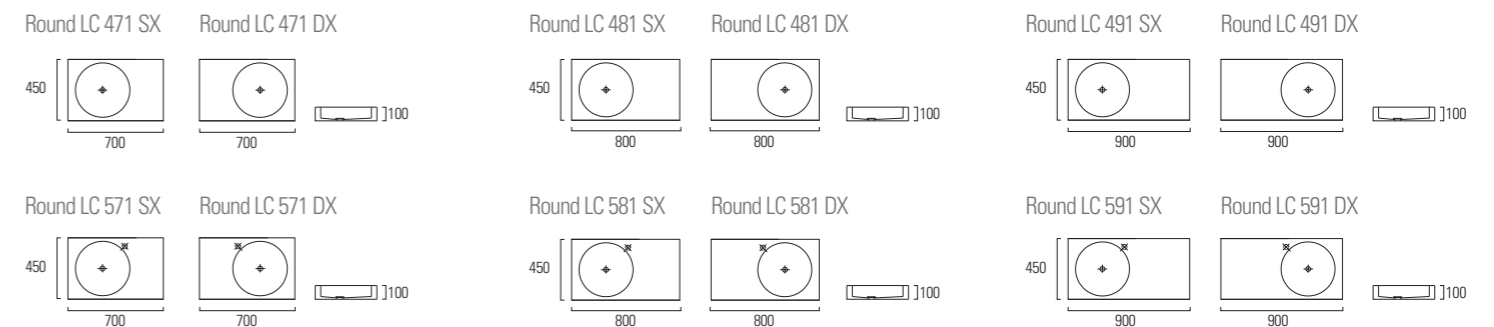

ROUND TAILOR by nespoli e novara

Round Tailor

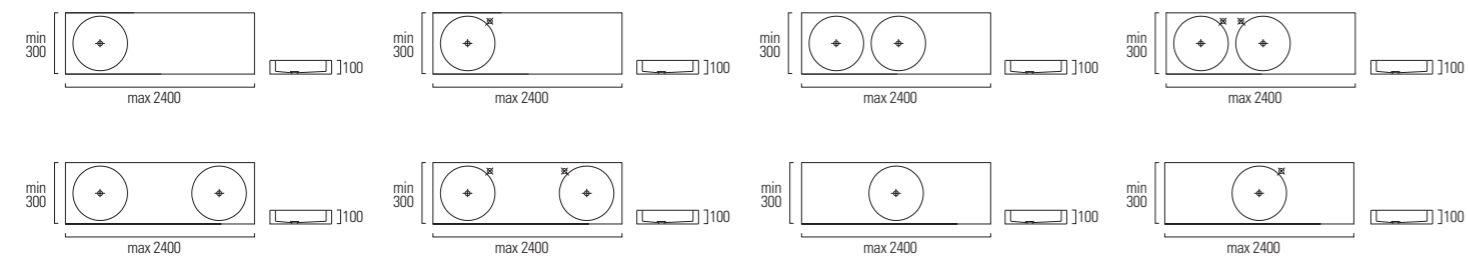

SLIDE by CRS

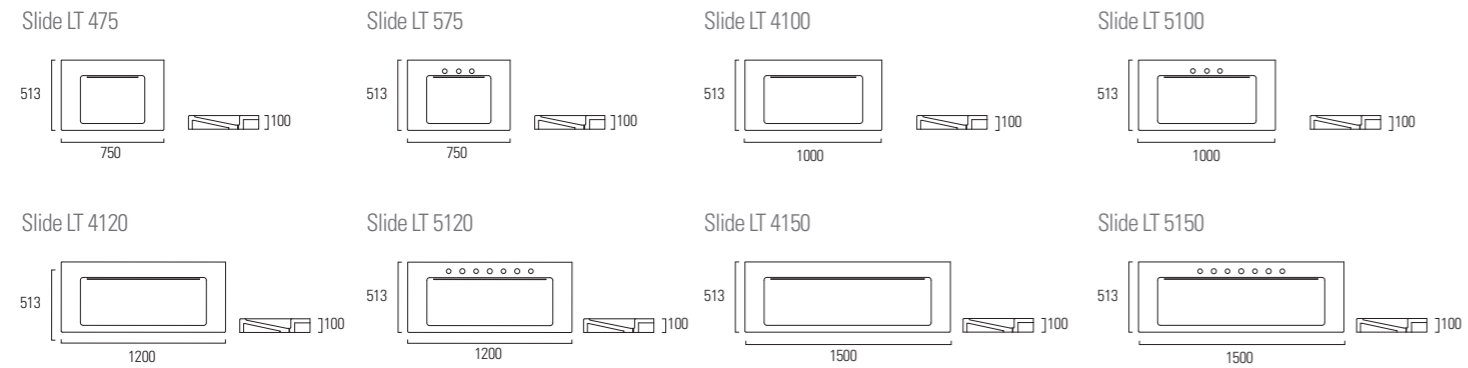

FLUID by CRS

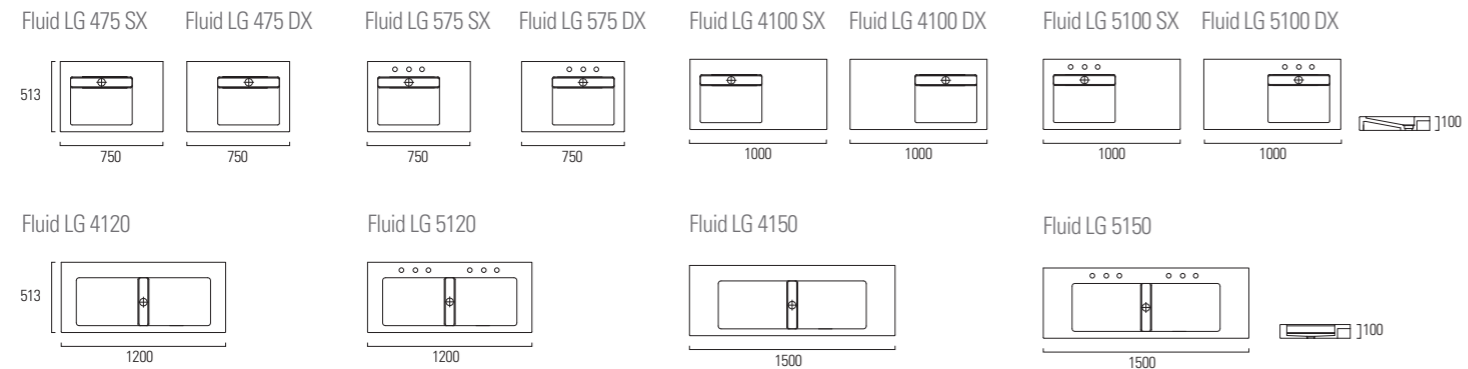

MONOLITI - MONOLITHS by nespoli e novara

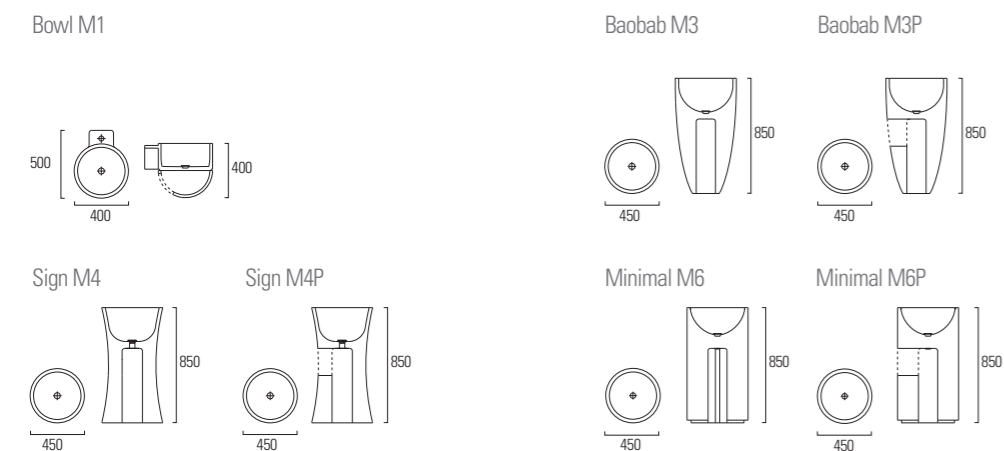

VASCHE - BATHTUBS by nespoli e novara

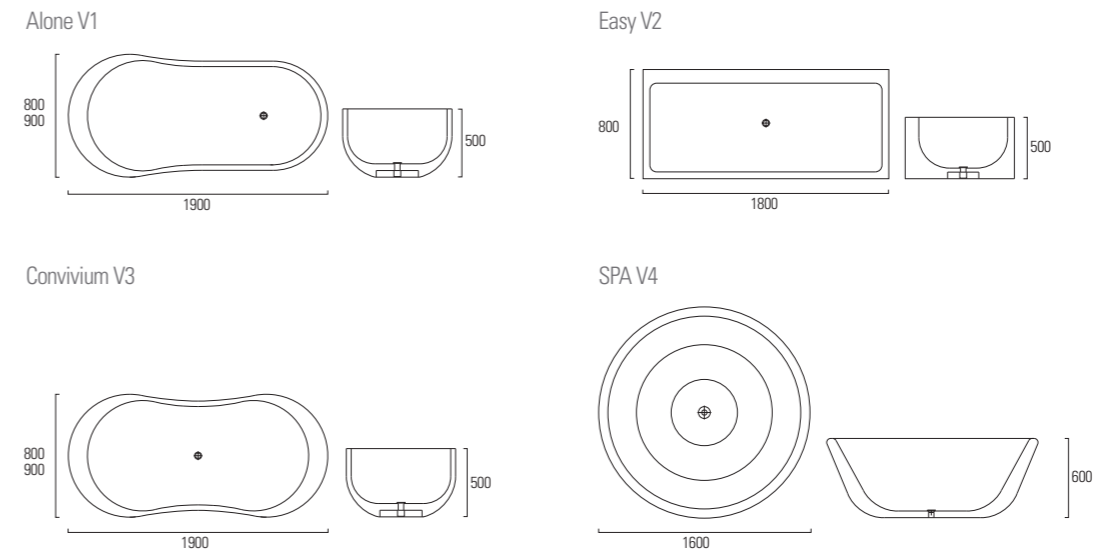

PIATTI DOCCIA A MISURA - TAILORED SHOWER TRAYS by nespoli e novara



RIVESTIMENTI - TILES by nespoli e novara

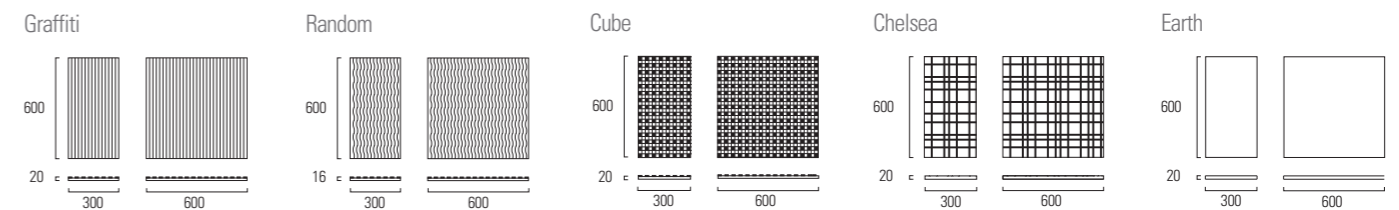

AUGMENTED TEXTURE by Elia Nedkov

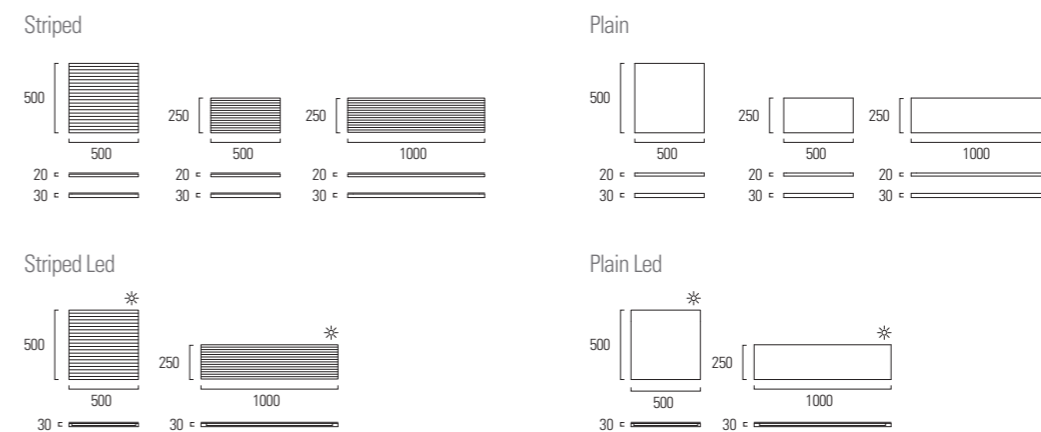

MOOD by nespoli e novara

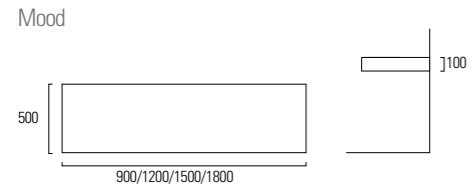

PLANA by CRS

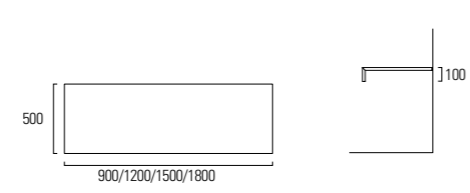

SOUL by CRS

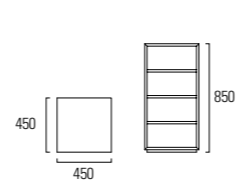

NEOS COLLECTION by Luca Martorano

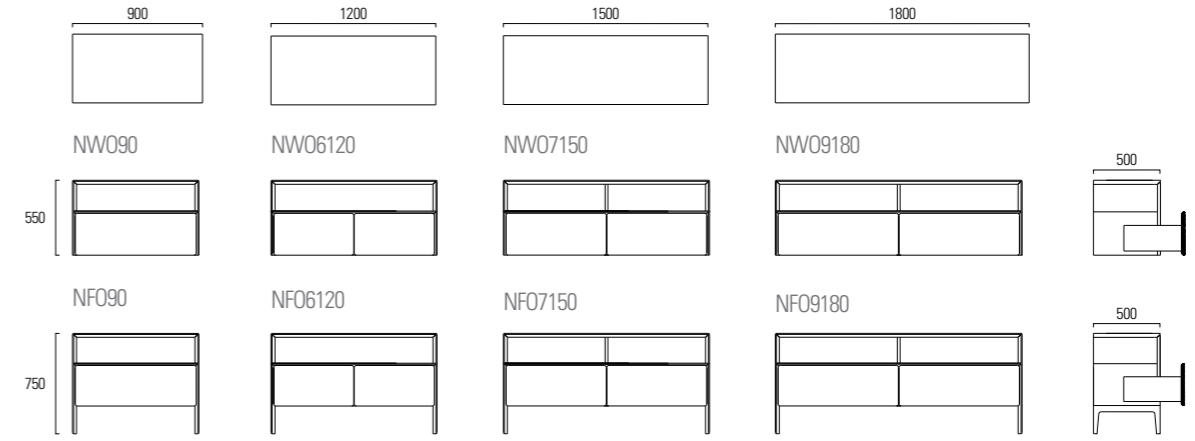

BRIDGE-DUAL by nespoli e novara

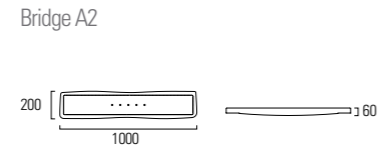
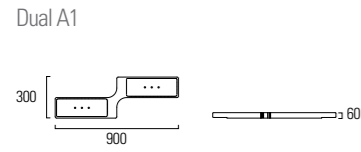

NEOS COLLECTION by Luca Martorano

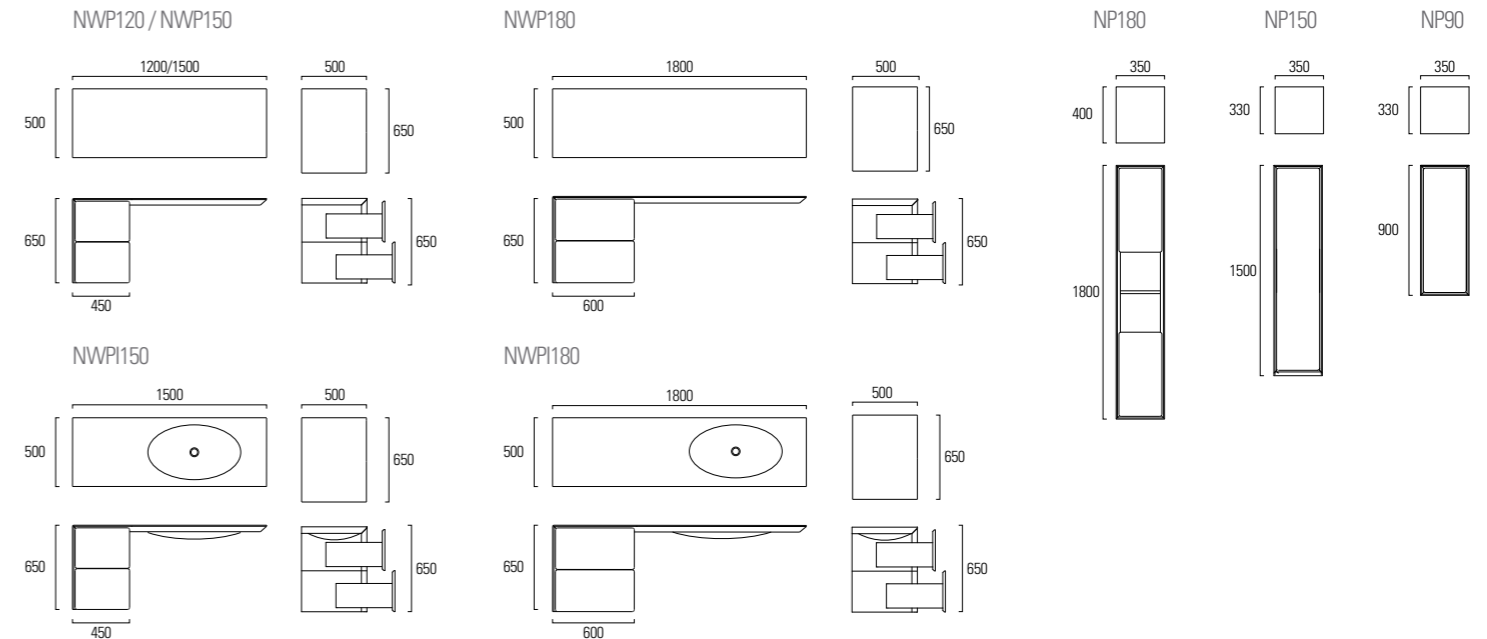
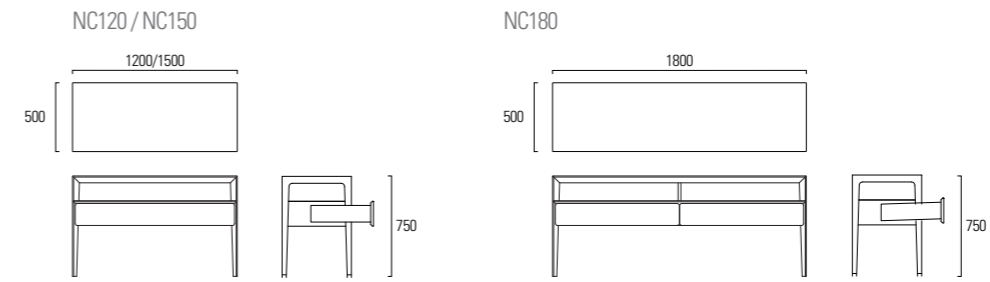
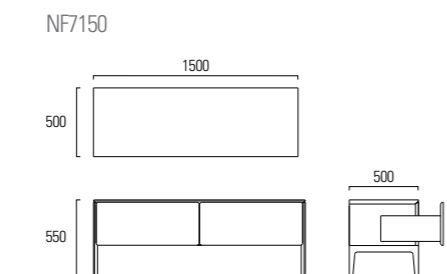
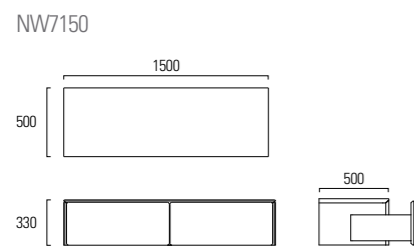
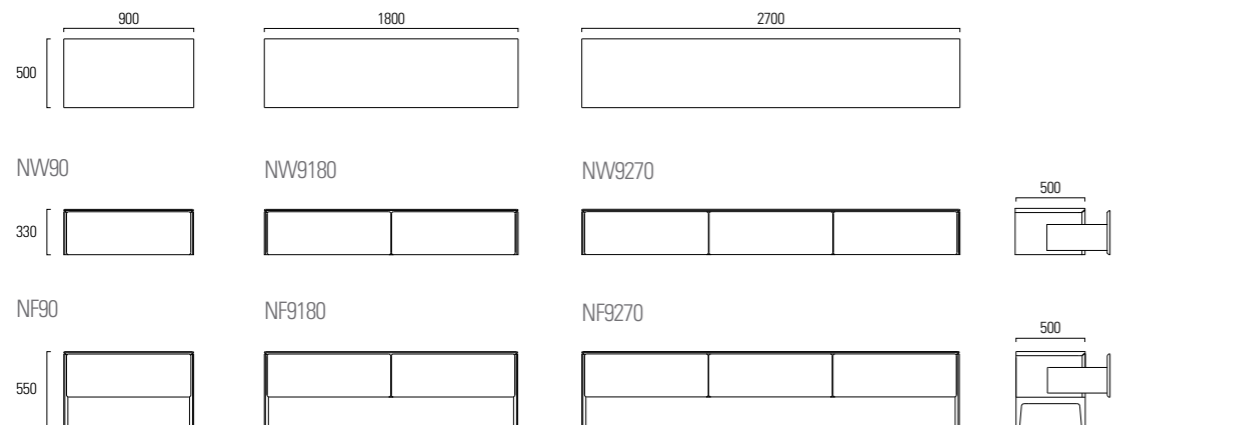
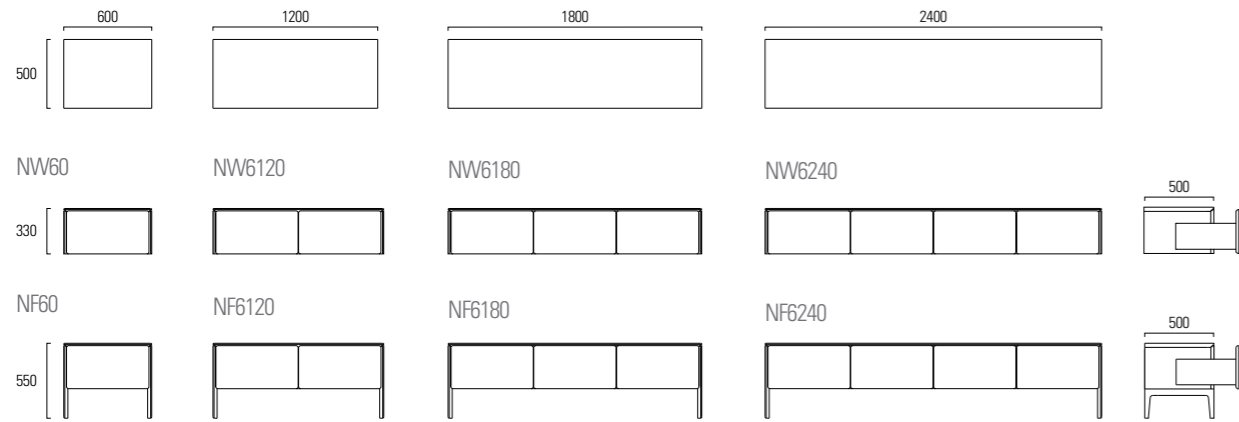

MOODY by CRS

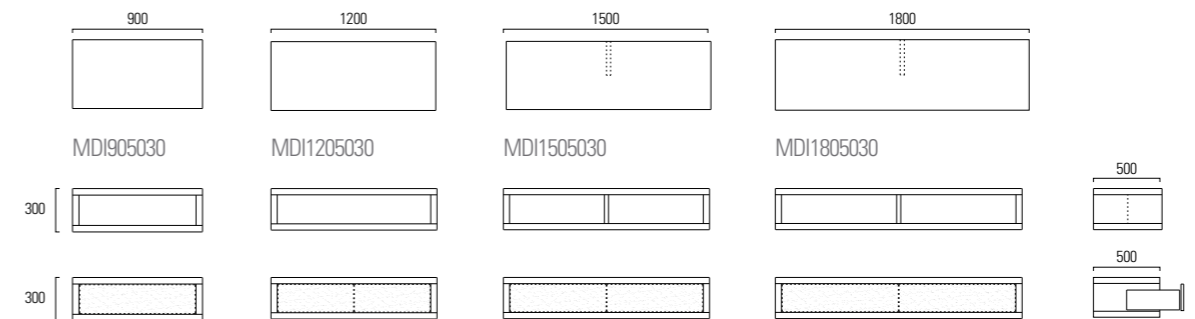

NEUTRA

by Arnaboldi Angelo srl
via Parigi 30
20831 Seregno MB Italy
T +39 0362 246708
F +39 0362 325277
info@neutradesign.it
www.neutradesign.it

Made in Italy
NEUTRA® è un marchio registrato - registered mark

concept and graphics

marco strina

photographs

tiziano sartorio

bruno pulici

styling

natascia vuk

luca rossire e daniela taranto

sissi valassina

copy

duccio biasi

postproduction

stefania pulcini

claudia zorzi

graphic assistant

barbara rosso

prepress

UPstudiomilano_roberta roselli

translation

john edmonds

general coordination

benedetta arnaboldi

roberto giavon

etienne marelli

print

galli thierry_milano

04.2016

thanks to

artemide_www.artemide.it

barovier&tosso_www.barovier.com

cea design_www.ceadesign.it

dornbracht_www.dornbracht.com

flos_ww.flos.it

fumagalli&dossi/gipsoteca milano_www.fumagallidossi.com

giada barbieri_www.giadabarbieri.com

I + I_www.i-and-i.it

ivano redaelli_www.ivanoredaelli.it

rapsel_www.rapsel.it

riva1920_ww.riva1920.it

sumampa_www.sumampa.com

vola_www.vola.com

warli_www.warli.it